

SPEED SHIFT
SINGLE COIL

10SS01

info@omextechnology.co.uk

www.armtech.co.uk



The Speed Shift works on most negative earth contact breaker ignition systems, opto breaker systems and most transistorised and ECU controlled ignition systems. It can be adjusted to any engine speed from 1,000 sparks-per-minute to 40,000 sparks-per-minute (e.g. 500 RPM to 20,000 RPM 4 Cylinders).

INSTALLATION PROCEDURE

1. Mount the clutch switch (supplied) above the clutch pedal, as shown in Fig 1. Using two nuts and washers, lock the switch into position such that the switch loses contact with the pedal itself when the pedal is depressed to its halfway position. The clutch switch must have good electrical contact with the vehicle's chassis EARTH.

2. Using the self-adhesive pads on the underside of the unit, securely mount the unit on top of the dashboard directly in front of the driver with the LEDs and push buttons facing the driver.

3. Using the wires and connectors provided, with the ignition turned off, connect the Speed Shift to the coil as follows;

- GREEN** To a good earth point near the coil
- RED** To coil positive (or, if this is not available, to any positive feed that is switched by the ignition).
- BLACK** To the coil negative (-)

BALLAST RESISTORS

If the ignition system to which the Speed Shift is to be connected incorporates a ballast resistor connected to the positive (+) terminal of the coil, then attach the RED wire of the Speed Shift to the ignition switch side of this resistor and not to the coil side.

SETTING UP

1. **Rev Limiter** - Start the engine. Press in the push-button switch labeled 'Set Rev Limiter' and hold. When the red LED stops flashing and remains lit, Hold the engine to half your required maximum speed, then release the button. The Speed Shift will immediately double and store this speed it in its memory.

2. **Shift Up Light** - To set the Ultra-bright red Shift-up light, start the engine. Press in the push-button labelled 'Set Shift Up' and hold. When the red LED stops flashing and remains lit. Hold the engine speed to your required shift up point (actual speed not half speed), then release the button. The Speed Shift will immediately store this speed it in its memory.

3. **Shift Down Light** - To set the Ultra-bright green Shift-down light, start the engine. Press in the push-button labelled 'Set Shift Down' and hold. When the green LED stops flashing and remains lit. Hold the engine speed to your required shift down point (actual speed not half speed), then release the button. The Speed Shift will immediately store this speed it in its memory.

4. **Full Throttle Gear Shift** - Start the engine. Press in the pushbutton switch labelled 'Set Gear Shift' and hold. When the green LED stops flashing and remains lit. Hold the engine at a speed halfway between the engine speed which is normally used to pull away from the start-line and the engine speed at which changing gear normally takes place, then release the button.

If the clutch pedal is now pressed when the engine speed is above the Gear Shift speed, the Speed Shift will assume that the driver is attempting to change up a gear under full throttle. It will therefore introduce a secondary rev limit which will be set to the exact speed at which the engine is running when the clutch pedal was pressed. This allows the driver to safely change up gear without lifting off the throttle pedal. If the clutch pedal is pressed when the engine speed is below the Gear Shift speed, the Speed Shift will assume that the driver is not changing up but preparing to start the engine. The Speed Shift will not introduce this rev limiter as it may hinder acceleration off the start.

5. **Settings** - All settings can be re-adjusted at any time by repeating the above procedure. These settings will not be lost if the battery is removed from the vehicle for long periods of time.

WIRING DIAGRAMS

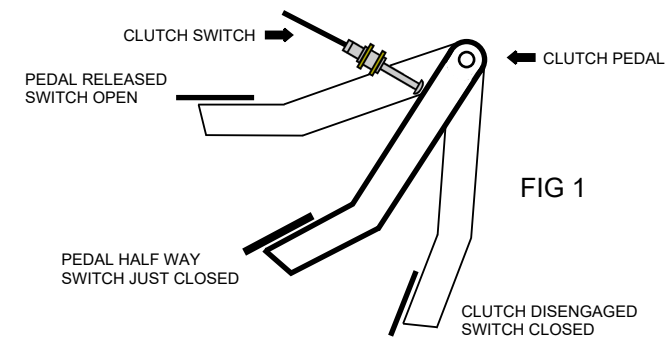

FIG 1

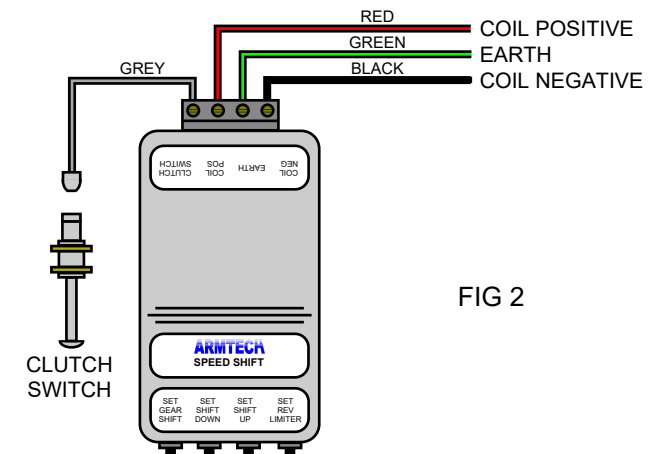

FIG 2

CUSTOMER CARE

As part of our commitment to providing the best possible products and after-sales service, we operate a telephone Help line and Warranty Care service. For any queries, just call during office hours or email and we will endeavour to resolve the problem.

WARRANTY

ARMTECH warrants that if the whole or any part of the SPEED SHIFT is defective as to materials or workmanship, provided that such defect is notified to ARMTECH as soon as the customer becomes aware and in any event within one year of purchase from ARMTECH or one of its distributors, ARMTECH will make good the said defect without charge by repair or, at the discretion of ARMTECH, by replacement. The warranty does not extend to defects caused wholly or partly by improper use, failure to follow installation or operation instructions, wilful default, act of God, or accident. ARMTECH will not be held liable for any injury, damage, direct or consequential loss, however caused relating to the ARMTECH

Attention. Within the EU, used electrical and electronic equipment should not be mixed with general household waste; it must be treated separately and in accordance with legislation that requires proper treatment, recovery and recycling. Private households may return their used electrical and electronic equipment to designated collection facilities free of charge. If the product is used for business purposes and you want to discard it, small quantities may be taken back by your local collection facilities. Please contact your local authority for further details. Outside of the EU, please contact your local authority for advice.

